

Parts - Pièces

Frame

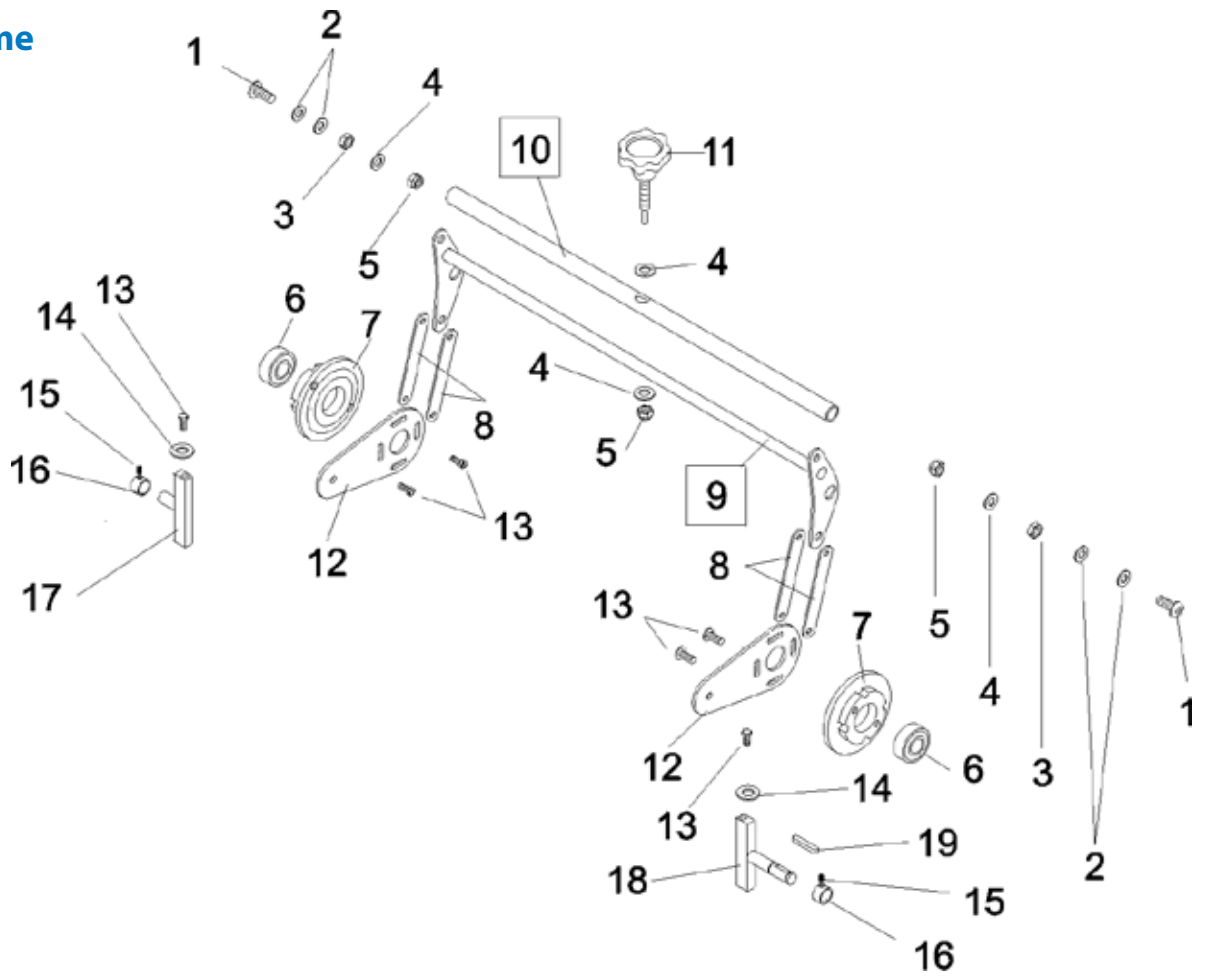

Side Brush

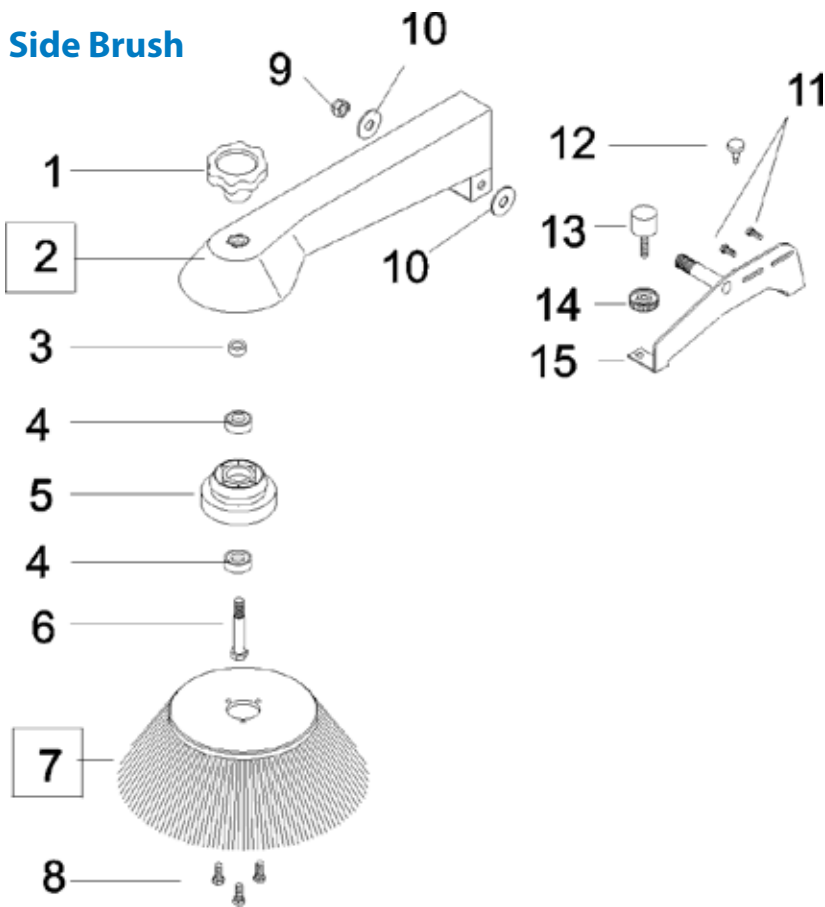

Frame

Ref.	Part N.	Description	Quantity	Validity From	Validity To
1	3VTVT00017	SCREW TE UNI 5739 8X35 ZB	2		
2	3VTRS87283	WASHER D.8X24X2,5 ZB UNI 6593	4		
3	3VTDD00483	NUT M 8 ZIN UNI 5588	2		
4	3VTRS00504	WASHER D. 8 TE ZC. UNI 6592	4		
5	3VTDD00124	NUT M 8	3		
6	3CUVR00005	BEARING 6202 2RS	2		
7	3LAFN26583	BEARING	2		
8	3LAFN87142	BRACKET	1		
9	3LAFN26579	BALANCER	1		
10	3LAFN00033	TUBE	1		
11	3VTVR75767	HANDWHEEL D.60 M 12 x 67	1		
12	3LAFN00642	BRACKET SUPP..	2		
13	3VTVT75719	SCREW TE F/ROND. M 6 X 10	6		
14	3VTRS04026	WASHER D. 6X18X2.38	2		
15	3VTVT75731	SCREW UNI 5923 6 X5	2		
16	3LAFN26588	SPACER LOLY 50	2		
17	3ALTR26577	BRUSH SHAFT LOLY 50	1		
18	3ALTR26587	TRACTION SHAFT LOLY 50	1		
19	3VTVR26559	KEY 5X5X15	1		

Side Brush

Ref.	Part N.	Description	Quantity	Validity From	Validity To
1	3VTVR75766	HANDWHEEL D60 M10 (Z01.021)	1		
2	3LAFN26508	LATERAL ARM LOLY 50H-HE	1		
3	3LAFN26509	THICKNESS MM7 LOLY 50	1		
4	3CUVR00003	BEARING 6201 2RS	2		
5	3MTPL26511	PULLEY 82 -1Z LOLY 50	1		
6	3LAFN26513	PIN LOLY 50	1		
7	3SPPV24794	SIDE-BRUSH LOLY 50-70	1		
8	3VTVT75719	SCREW TE F/ROND. M 6 X 10	3		
9	3VTDD00042	NUT AUT.M10 UNI7474	1		
10	3VTRS00505	WASHER D.10 TE UNI 6592	2		
11	3VTVT63129	SCREW TE F/ROND. M 8X16 ZB	1		
12	3ABGO00011	VIBRATION DAMPER	1		
13	3ABGO26555	VIBRATION DAMPER	1		
14	3LAFN26557	RING NUT M 8 D.40	1		
15	3LAFN26574	ARM SUPPORT LOLY 50	1		

Parts - Pièces

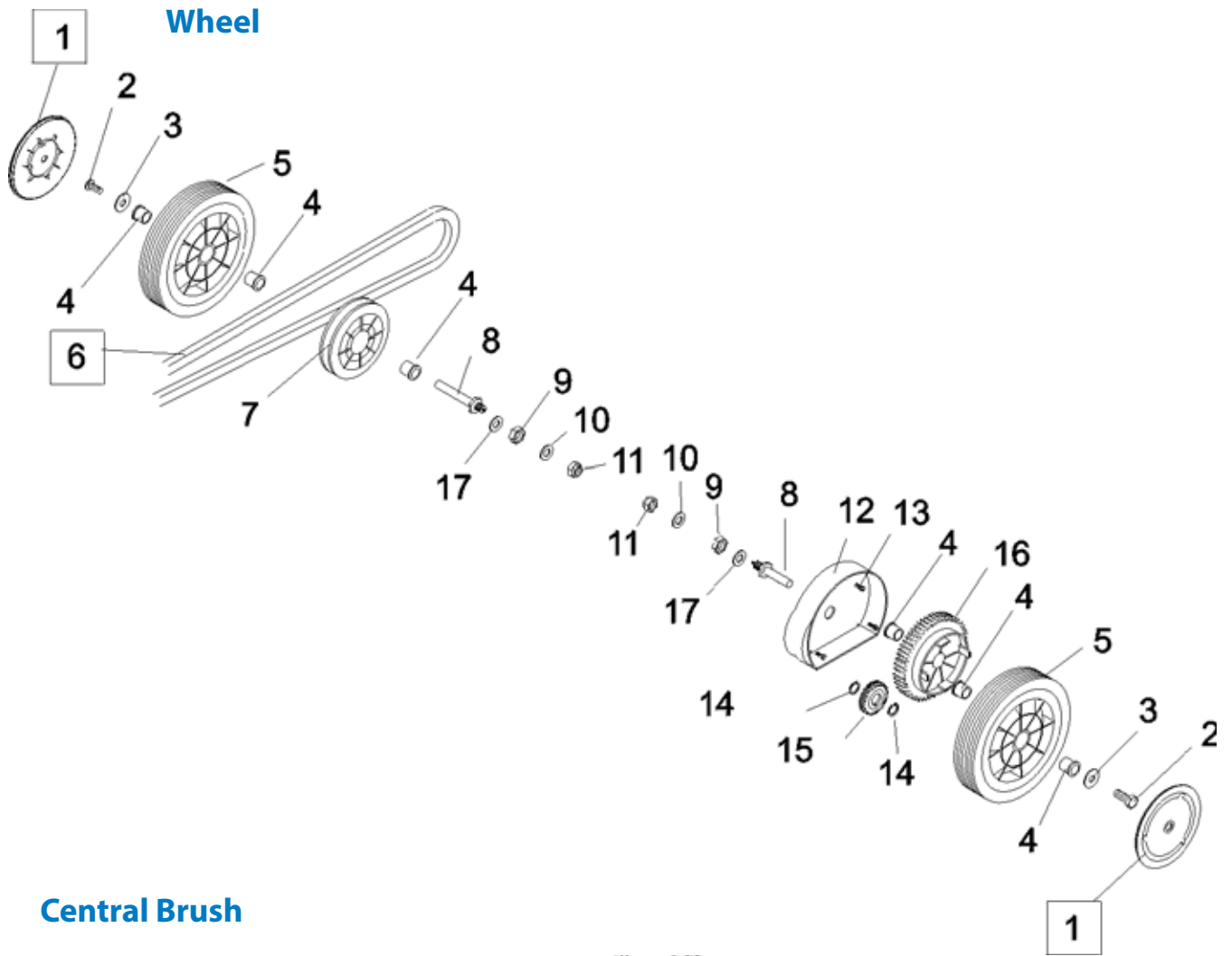

Central Brush

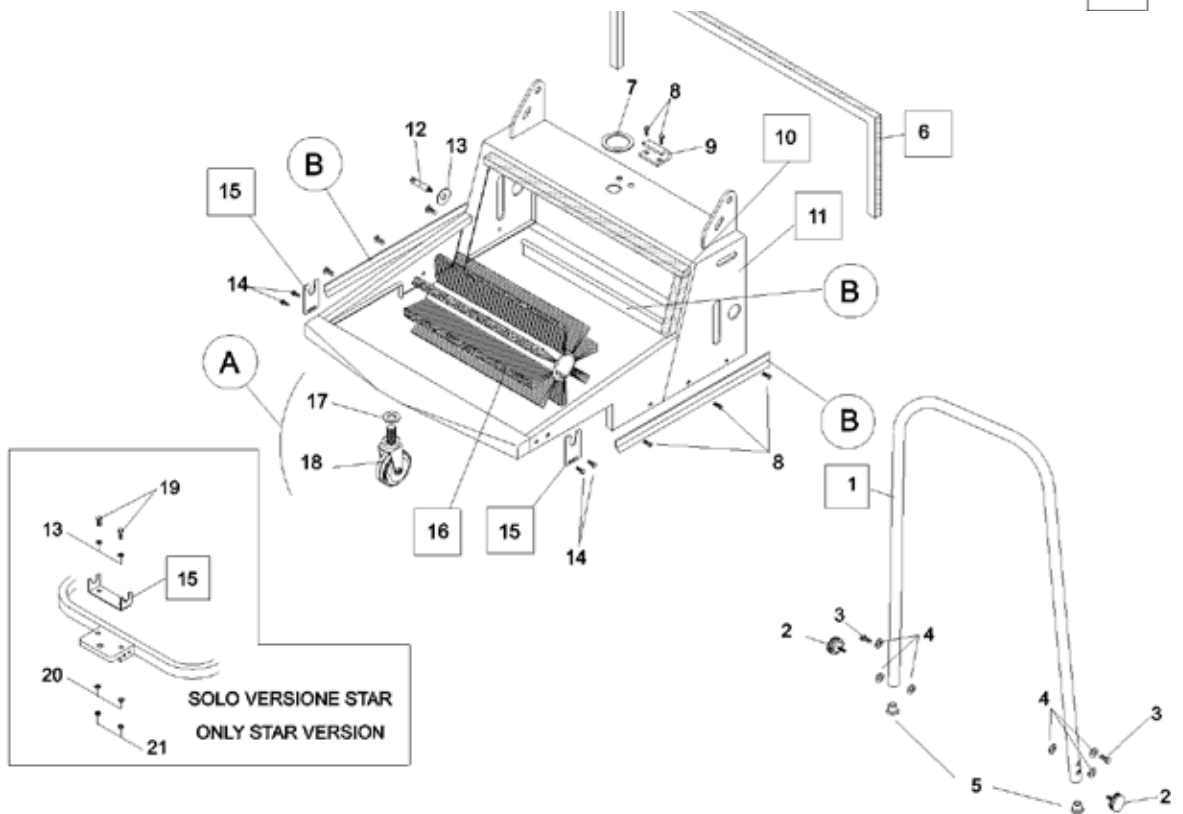

Wheel

Ref.	Part N.	Description	Quantity	Validity From	Validity To
1	3MPVR00159	WHEEL'S COVER D.250 NERO	2		
2	3VTVT75719	SCREW TE F/ROND. M 6 X 10	2		
3	3VTRS63242	WASHER D. 6 X24 ZC	2		
4	3MPVR26573	BUSHING D.15X20NYL	6		
5	3RTRT37325	WHEEL D.250-D.20 SP	2		
6	3MTCG26512	BELT Z 64 10X1620	1		
7	3MTPL75982	PULLEY DE 178 M	1		
8	3LAFN00422	PIN	2		
9	3VTDD00015	NUT UNI 5589 M18 ZB	2		
10	3VTRS00512	WASHER D. 8 X24 ZC.	2		
11	3VTDD00124	NUT M 8 BASSO	2		
12	3MPVR75847	SIDE CRANKCASE I	1		
13	3VTVT00040	SCREW AUTOF.TC UNI6954 3,5X10SP	1		
14	3VTAE17003	CIRCLIP D. 15 UNI 7435	2		
15	3MTIG26560	TOOTHED WHEEL Z= 14 M. 3	1		
16	3MTIG26563	TOOTHED WHEEL Z= 44 M. 3 D.138 M	1		
17	3VTRS00013	WASHER UNI 6592 18X34 ZB	2		

Central Brush

Ref.	Part N.	Description	Quantity	Validity From	Validity To
1	3LAFN00382	HANDLE	1		
2	3VTVR26552	HANDWHEEL M 8MAX15 D.40	2		
3	3VTVT63129	SCREW TE F/ROND. M 8X16 ZB	2		
4	3VTRS00504	WASHER D. 8 TE ZC. UNI 6592	6		
5	3VTVR00039	PLUG	2		
6	3KTRI00012	KIT GASKET	1		
7	3ETET00003	LABEL	1		
8	3VTVT00040	SCREW AUTOF.TC UNI6954 3,5X10SP	2		
9	3CHVR85161	CLOSING HOOK	1		
000B	3MPVR38013	RUBBER FLAP	1		
10	3KTRI00013	KIT GASKET MOUSSE	1		
11	3LAFN00989	FRAME	1		
12	3LAFN75969	PIN D.9 H.33	1		
13	3VTRS63242	WASHER D. 6 X24 ZC	3		
14	3VTVT85116	SCREW TE FR 6,3X19 ZIN	2		
15	3LAFN00648	BASE-SUPPORT	2		
16	3SPPV24793	CENTRAL BRUSH LOLY 50 H	1		
17	3VTRS00506	WASHER D.12 UNI 6592	1		
18	3RTRT75981	TURNING WHEEL D.80	1		
19	3VTVT62920	SCREW TE F/ROND. M 6X 16 ZB	2		
20	3VTRS04026	WASHER D. 6X18X2.38	2		
21	3VTDD00482	NUT M 6 ZIN UNI 5588	2		